

3D Display Systems Hardware Research at Sharp Laboratories of Europe : an update

シャープ欧州研究所における3Dディスプレイハードウェアの研究 最新状況

Jonathan Harrold* Adrian M. S. Jacobs* Graham J. Woodgate* David Ezra*

Abstract

New three dimensional (3d) displays exploiting patterned retardation elements (i) external and (ii) internal to the LCD are discussed. The fabrication of a 13.8" diagonal patterned retardation element from reactive mesogen, which co-operates with a polariser to form a parallax barrier, is described.

An electrically switching LC cell demonstration incorporating a *polariser and retarder array inside the LC cell itself* has been fabricated and results are presented.

パターン化した波長板素子を液晶の (i) 外部および (ii) 内部に活用した, 新規の3Dディスプレイについて論じる。偏光板と組み合わせることによって視差バリアとなる対角 13.8 インチのパターン化した波長板素子を, 活性高分子(リアクティブ・メソゲン)を用いて作成する方法についても紹介する。液晶セル内に偏光素子と波長板アレイを組み込んだ, 電気的にスイッチする液晶セル構造を試作し, その結果についても報告する。

Introduction

Autostereoscopic (no-glasses) 3d displays [1] produce an optical output such that at a region in space at least two pupils or windows are created as shown in **Fig. 1**. If an observer places the right eye in one window, and the left eye in another, each eye sees a different image on the display. If the images constitute a stereo pair then a 3d image is seen, without the need to wear glasses.

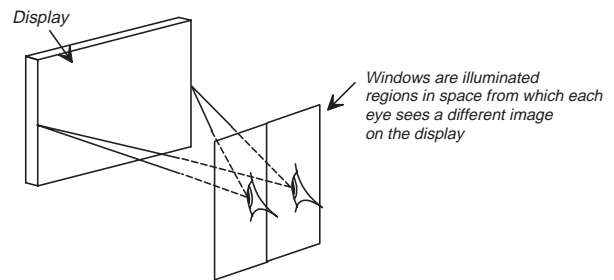

Fig. 1 Generation of windows in autostereoscopic displays.

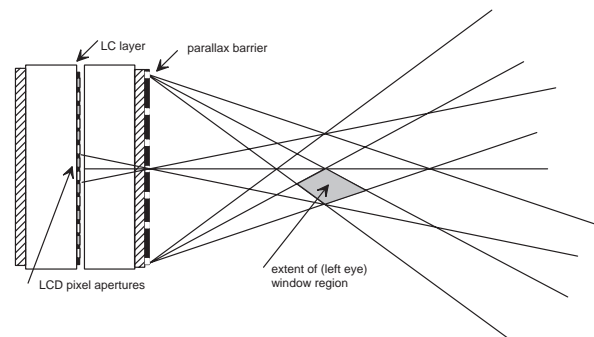

Fig. 2 Parallax barrier LCD display.

3d displays researched at Sharp Laboratories of Europe (SLE) and have been described previously in this journal [2, 20], and the optics of a technology demonstrator based on a (minimally modified, **Photo 1**) Sharp CE-LT14 monitor and a LQ14X03 LCD panel with a front parallax barrier designed at SLE is illustrated in **Fig. 2**. In this paper we describe some recent display hardware research.

Whilst this type of display is agreeably sufficient for 3d, when displaying 2d data, the horizontal resolution is

* Sharp Laboratories of Europe, Ltd.

halved. In addition the parallax barrier aperture transmission is $\sim 30\%$, reducing the brightness of the display. The barrier also produces images of black bars in the window plane corresponding to the electrode structure of the panel. These are all major issues when such a 3d display is displaying 2d data.

A novel solution to the aforementioned issues is the subject of SLE patent applications [3, 4] and is illustrated in **Fig. 3**. This invention exploits the polarised light output from a standard LCD, a patterned retarder array, and an additional polariser to replace the absorptive parallax barrier of **Fig. 2**. The optical configuration of this display and the fabrication of the retarder barrier element is described below. The key points are: -

- ◆ 2d mode is full resolution.
- ◆ 2d mode can be full brightness (as the eye is not sensitive to polarisation).
- ◆ An additional polariser is attached on to the front of the display to enable 3d mode.

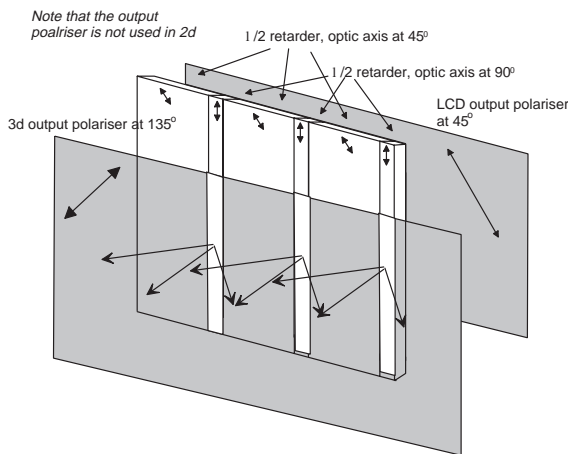

Fig. 3 Retarder Prallax barrier configuration.

1. Reactive mesogen

Reactive Mesogen (RM) materials have similar birefringence and alignment properties to low-molar-mass liquid crystals but additionally may have their orientation substantially fixed by UV initiated polymerisation. The high birefringence (Δn about 0.16), the temperature stability of the polymerised films [6] and LC-like surface aligning properties of RM enable fabrication of polarisers

[6], colour filters [7], retardation plates [7] and more specifically patterned retardation plates [3]. The reader is referred to [5] and the references therein for further information on RM.

These materials are exploited at SLE as they are eminently suitable for forming the high resolution patterned arrays necessary for use in a novel 2d/3d switching autostereoscopic display [4] and in novel micropolariser displays [9].

1•1 Retarder barrier requirements

For an XGA resolution 13.8" parallax barrier 3d display, the pitch of the barrier is about $180\mu\text{m}$, and the slit width is below $70\mu\text{m}$. The accuracy requirement across the display is better than 1 part in 2000. Therefore the retarder barrier element must be produced exceedingly accurately. Variations in the slit width will result in variations in brightness and indeed cross talk between the left and right images [20]. If the accuracy specification is not met, it will result in failure of the parallax barrier to create the correct windows (as in **Fig. 1**), and the 3d effect will not be visible over the entire display.

2. Commercially available retarder arrays

Retarder arrays which alternate a stripe of stretched polyvinyl alcohol (PVA) with isotropic material fabricated by cutting or etching is described in [22]. The birefringence of PVA material is comparatively low (Δn about 0.02), and therefore the half-wave retarder made from this material is about $10\mu\text{m}$ thick. The resolution and accuracy requirements (see section 2•1) for XGA and future displays make fabrication by cutting difficult. The thickness of the PVA layers means that edge definition in etching processes may be difficult to control, and may limit practical resolution, particularly if the etching is at an angle to the stretching direction. Retarder arrays of this type have been commercially used in 3d products [10].

These displays orient the retarder stripes horizontally so that "odd" and "even" lines of the panel have orthogonal polarisation and correspond to the "left" and "right" images respectively. The viewer wears polarising glasses. In the direct view display version the unwanted parallax between the retarder array and the LC pixel plane greatly limits the viewing freedom [11] even when wearing polarising

glasses.

The birefringent element from a commercially available retarder array has been measured at SLE and the result is shown in Fig. 4. The transition between regions is seen to be about 60μm wide, which is of the same order as the required slit width for 13.8" XGA parallax barrier. Much higher precision is required for good quality low cross talk autostereoscopic 3d displays.

2•1 Research at SLE

At SLE we have determined that retarder arrays using coated RM material that is patterned by a single surface alignment layer can meet the parallax barrier specification (section 1.1). The other surface of the RM may be an air interface. The alignment is rubbed polyimide, or LPP [7]. By adjusting the coating conditions we have been able to produce a wide range of retardation values. Using a multi-rubbing process [12] developed at SLE, high accuracy and good cosmetic quality 2d/3d parallax barriers may be produced suitable for 13.8" XGA LCD.

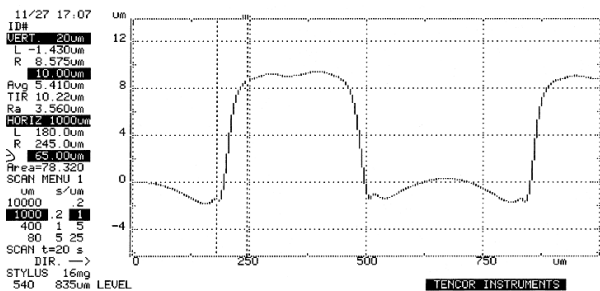

Fig. 4 Profile measurement of commercial retarder stripes.

2•2 Detailed description of fabrication.

The retarder array illustrated at fig. 3 which includes regions of the same magnitude retardation ($\lambda/2$), but different orientation, allows us to match the absorption properties of the two regions in 2d and offers superior performance to the ($\lambda/2$, zero) retardance stripe array with regard to Moire fringes. The technique described below allows a single mask step fabrication of patterned retarders: -

- ◆ A 1.1mm glass substrate is cleaned and coated with

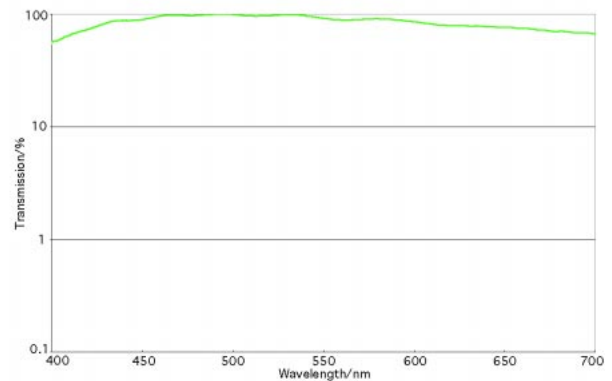

Fig. 5 Transmission of RM retarder.

polyimide PI2555 (Dupont) diluted 1:20 with T9039 solvent.

- ◆ The substrate is then uniformly rubbed with a YA-20 cloth with 0.2 mm pile deformation at 3000rpm roller speed with a 20mm s⁻¹ table speed.
- ◆ The substrate was then coated with photoresist S1805 (Shipley) followed by a 2 minutes 95 °C hot plate pre-bake.
- ◆ Contact mask with exposure 20mJ cm⁻².
- ◆ Develop, wash and dry in order to create one set of striped regions while leaving the other set protected by photoresist.
- ◆ Oven bake for 50 minutes at 110 °C.
- ◆ Second rub at a different angle with the same conditions as above.
- ◆ Dip in acetone for 2 minutes, then de-ionised water for 3 minutes and oven dry for 1/2hr at 150 °C.
- ◆ Coat the reactive mesogen in solution [16].
- ◆ Cure the RM at 2J cm⁻² in the absence of oxygen.

This method has been recently adapted to produce a retarder barrier suitable for a 2d/3d 13.8" XGA using facilities and with the co-operation of Sharp ETDC. A mask aligner was used as a convenient source of UV for the contact mask photoresist exposure and also for the RM curing rather than a UV light box. The "mask alignment" function was not necessary in this case.

Some control of the curing process is needed in order to avoid the occurrence of splay in the retarders. Splay results in non-uniform off axis contrast performance. Since the curing process is inhibited by the presence of oxygen, we believe that the films tend to cure from the alignment layer

side upwards. This process helps to pull down the director of the RM at the air surface and reduce splay. It is therefore also preferable to use a low tilt alignment layer for this application.

2•3 Results

The above technique has been used to produce patterned retarder arrays of both stripe and checkerboard test patterns as well as retarder parallax barriers. **Photo 2** shows a $\lambda/2$ checkerboard retarder array with $100\mu\text{m}$ squares between crossed polarisers. The optic axis in the fully black regions is aligned with the LCD output polarisation axis. The transmission through the "white" squares in this configuration is at an angle to the output polarisation and therefore slightly chromatic as shown in **Fig. 5**. The half-wave film thickness is about $1.5\mu\text{m}$.

A 2d/3d display using a retarder array patterned in the form of a parallax barrier by the techniques in this paper is illustrated in **Fig. 6**. The barrier section has an optic axis of the retarder aligned to the output polarisation of the LCD so that there is no chromatic effect and the extinction of the barrier part is effectively determined by the performance of the LCD output polariser crossed with the additional 3d polariser. An extremely good black state is needed in order to minimize the 3d image cross talk. The optic axis of the $\lambda/2$ retarder in the slit section is aligned at 45 degrees to the output polarisation of the LCD so that light from the LCD passing through it is rotated by 90 degrees and is maximally transmitted by the 3d polariser.

When the LCD output polarisation is itself inclined at 45 degrees as typical of TFT panels, then the optic axis of the slit section is aligned at or close to the (vertical) slit direction (see **Fig. 3** and **6**) which further improves the ease of fabrication by the multi-rubbing process [12].

2•4 Reactive mesogen manufacturing issues

In the autostereoscopic 3d application the retarder element was fabricated separately and attached to the finished LCD display. In this case materials need not be of the same purity as is required for polyimide or RM which is actually incorporated within the LC-cell itself. This augurs well for low cost production.

The 13.8" patterned retarder arrays produced in this work have endeavoured to use alignment layer materials

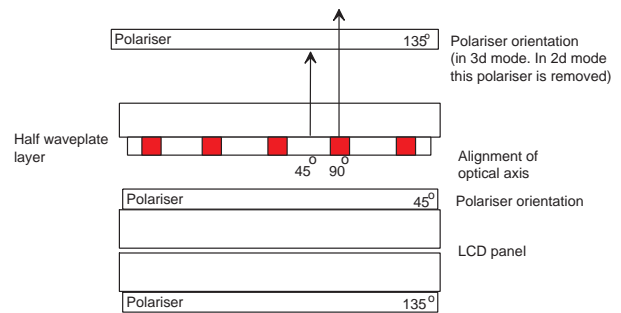

Fig. 6 2d/3d display configuration.

and processes such as rubbing, spinning, washing and photoresist lithography typical of LCD fabrication.

3. LCD-internal optical elements

In addition to external retarder arrays, there are many advantages to be gained from displays with internal retarders and retarder arrays in combination with internal polarisers. This latter case can produce a particularly powerful class of LCD suitable for both glasses and no-glasses type 3d. This eliminates the unwanted parallax problem of [8], and enables, (in the stereoscopic version), multiple viewers with unconstrained viewing freedom, and has a full resolution, full brightness 2d mode obtained by removing the 3d glasses. One configuration of such a display [9] is illustrated in **Fig. 8**.

3•1 LCD-Internal retarder

For incorporation inside an LCD, particularly a TFT LCD, there are stringent requirements which include:-

- ◆ Material purity (affects voltage holding ratio)
- ◆ Processing temperature endurance
- ◆ Retarder variation with temperature
- ◆ Solvent resistance
- ◆ Long term stability
- ◆ Thickness variation

Many of the 3d configurations described in [9] require internal elements to be disposed on only one internal surface. This is a great advantage in the case of active matrix panels where it becomes desirable to locate the internal optical element layer(s) on the counter (i.e. non-

active) substrate. In this case the RM material must be able to withstand the alignment layer processing solvents and temperatures. The temperature stability of RM layers is reported in [6].

While it is possible to configure a transparent electrode layer on either side of the RM layer, the voltage drop across the RM must be considered if it is placed below.

3•2 LCD-internal polariser.

LCD internal polarisers [21] are considered to have potential advantages for plastic displays, where birefringent substrates can be used, potentially also in LCD projectors where high temperatures are reached, and in other applications where increased ruggedness is of benefit. Once incorporated, the LCD substrate provides considerable protection for an internal polariser.

If the polariser is to be incorporated within the LC cell then it too must satisfy the requirements mentioned above. A specification for an *ideal* polariser for LC cell internal application would include:-

Contrast ratio (CR) of greater than 200:1 over the visible spectrum

- Transmission > 42%
- Flatness < 0.1µm
- Thickness < 2 µm
- Temp endurance ~200 °C for 2hour

Typical LCD-external polarisers are PVA doped with iodine, or dichroic dye [13], or a combination of the two. Experimental tests on cellulose tri-acetate (TAC) encapsulated iodine polarisers (which were specified to 80 °C) have been made at 140 °C and are shown in **Fig. 7**. The extinction performance was measured with a Linkam microscope hot stage, microscope polariser and attached EG&G spectrograph model 1235 with the detector cooled to 5 °C. This CR performance is inadequate for our purpose even at 140 °C. Dichroic dyes have been incorporated within reactive mesogen [6] and liquid crystal polymer [14] which may resolve the polariser temperature stability issue, but LC order parameter [15] prevents the CR and transmission specifications above being simultaneously achieved.

A new type of experimental polariser material "A" [17],

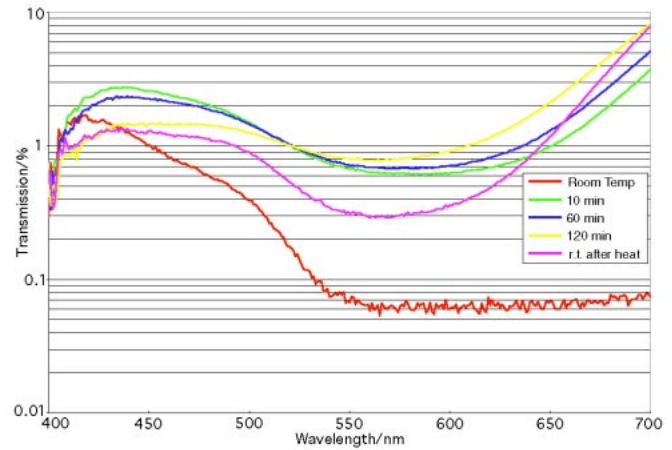

Fig. 7 Standard iodine polariser in extinction, heating to 140 °C.

which does not contain iodine, has been similarly temperature tested in unlaminated form and offers superior performance. Material "A" has been successfully incorporated inside electrically operating TN test cells. A transparent indium tin oxide (ITO) electrode was deposited on top of the polariser in one case; underneath the polariser in another. It is preferable to deposit the ITO on top of the polariser to avoid voltage drop across the polariser.

A further test in which type "A" and a modified type "B" polariser [17] were both laminated together inside the LC cell has also been made. This cell produces CR of substantially 200:1 across the visible spectrum. In both cases, the electrically operating experimental TN cells are 10µm thick and filled with E7 liquid crystal. The internal polariser was incorporated on only one internal surface of the cell.

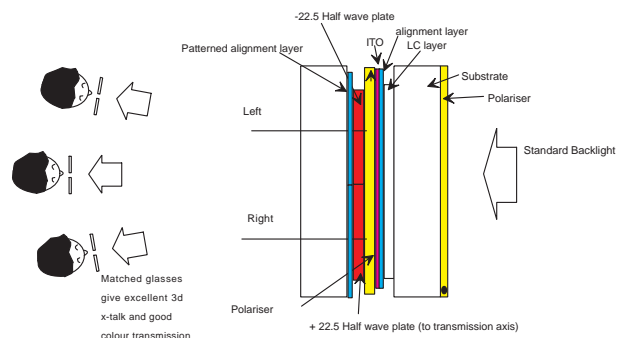

Fig. 8 Internal polariser 3d display.

3•3 LCD-internal polariser + internal retarder

Another test cell type with internal polariser and an internal patterned retarder array was fabricated, and is shown in **Photo 3** The finest stripe feature is 10µm wide. The arrangement of polariser and retarder axes is the same as described in section 2.3. This is the realisation of the structure of **Fig. 8** and augurs well for the practical potential of internal polariser 3d displays.

4. Applications for 3d displays

In addition to work at SLE, there has been recent interest in the potential of patterned optical elements for 3d from Samsung and MIT [18, 19].

Possible areas of application include game displays for PC and arcade units; education and edutainment; Internet browsing for remote 3D model browsing; scientific visualisation and medical imaging.

Conclusion

The main achievements of the programme to date include: -

- ◆ Precision external retarder barrier array applied to 2d/3d 13.8" XGA display.
- ◆ Electrically operating LC cell with internal polariser
- ◆ LC cell internal polariser combined with internal patterned retarder, suitable for a 2d/3d micropolariser display with full viewing freedom and no unwanted parallax effects

Acknowledgements

The authors gratefully acknowledge their colleagues in the Liquid Crystal Group for many discussions and the early process development work with reactive mesogen at SLE. Louise Affleck for some of the experimental measurements of polariser temperature performance. Merck UK limited for supply of RM samples and mixtures. Management and colleagues at Sharp ETDC for kindly making available the large area fabrication facilities and expertise. Finally we thank Corporate R&D Group for their continuing support of our work.



Photo 1 3d display.

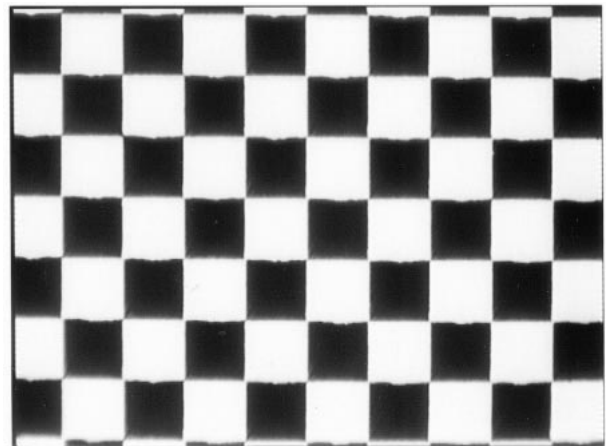

Photo 2 Retarder array (crossed polarisers).

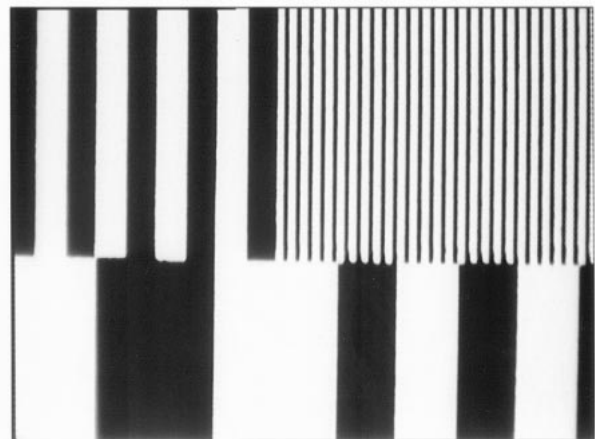

Photo 3 Internal polariser and retarder cell.

References

- [1] Three Dimensional Imaging Techniques. T Okoshi. Academic Press 1976.
- [2] D.Ezra, G.J. Woodgate, B.A. Omar, N.S. Holliman, J. Harrold and L.S. Shapiro "New autostereoscopic display system", pp10-14, Sharp Technical Journal Volume 62, August 1995.
- [3] EP 887 666 G. Woodgate, J. Harrold, A. Jacobs, D. Ezra. R. Mosely.
- [4] EP 829 744 R. Mosely, G. Woodgate, J. Harrold, A. Jacobs, D. Ezra.
- [5] D.J. Broer, "Molecular Architectures in Thin Plastic Films by In-situ Photo-polymerisation of Reactive Liquid Crystals" pp 165-168 SID95 Digest.
- [6] EP 397 263 Method of manufacturing a polarisation filter and display having such a filter. D.J. Broer.
- [7] M. Schadt, Japanese Journal of Applied Physics 34 no 6A p3240
- [8] US 5 537 144 Faris.
- [9] EP 721 132 G. Woodgate, J. Harrold, D. Ezra.
- [10] www.vrex.com
- [11] JP H10 268233 Sumida, Fujii, Shibatani, Hamada et al.
- [12] EP 887 667 A. Jacobs, E. Acosta, J. Harrold, H. Walton, M. Towler.
- [13] Mohri, S. Matsuo T. SPIE 2407 , Feb 95 "Highly Durable dyed Polariser for use in LCD projection"
- [14] US 5 851 423 Teng, Yoon, Shen.
- [15] Liquid Crystals Applications and Uses Vol 1. pp142 B. Bahadur (ed.) .World Scientific 1990.
- [16] RMM20 (Merck UK)
- [17] No further details are publicly available at this time.
- [18] J. Y. Son, et al. SPIE 99 vol. 3639 (1994) p132.
- [19] S.A. Benton, et al. SPIE Vol. 3639 (1999) pp76.
- [20] G. J. Woodgate, David Ezra, Jonathan Harrold, N. S. Holliman, G.R. Jones, R. R. Moseley "Observer Tracking Autostereoscopic 3D Display Systems", pp10-14, Sharp Technical Journal Volume 69, December 1997.
- [21] EP 887 692 A. Jacobs, J. Harrold.
- [22] US 5327 285 Faris.

(received May 21, 1999)